

(PL) Instrukcja montażu
 (D) Aufbauanleitung
 (GB) Assembly instruction
 (SK) Návod na montáž

Łóżko
 Bettgestell
 Bed
 Postel'

81242

(12-20)

⚠ UWAGA

Drogi kliencie, przed rozpoczęciem montażu upewnij się, czy posiadasz wszystkie niezbędne elementy pokazane w instrukcji.

W przypadku zamówienia mebla tapicerowanego tkaniną w takim samym kolorze jak zakupione wcześniej meble, może wystąpić różnica w odcieniach wybranej tkaniny.

⚠ ACHTUNG

Sehr geehrter Kunde. Bitte überprüfen Sie vor Beginn der Montage die Vollständigkeit unten aufgeführten Bauteile.

Bei einer Nachbestellung dieser Artikel können Farbabweichungen bei den gewählten Stoffen sein.

⚠ CAUTION

Dear Customer, before assembly, ensure that you have all the necessary elements specified in the instruction.

In case of ordering the same fabric in different time, the colour of fabric may be a little bit different.

⚠ POZOR

Vážený zákazník, pred montážou sa prosíme uistiť či v balení sú všetky potrebné diely znázornené v návode.

V prípade objednania textilie čalúnený nábytok v rovnakej farbe ako predtým zakúpeného nábytku, môže byť rozdiel v odtieňoch zvolenej látky.

Oznaczenia kontrolne
 Bezeichnungen steuern
 Control marks
 Označenie ovládat'



Elementy w paczkach
 Befestigungsmaterial im Paket
 Items in the packages
 Položky v balení



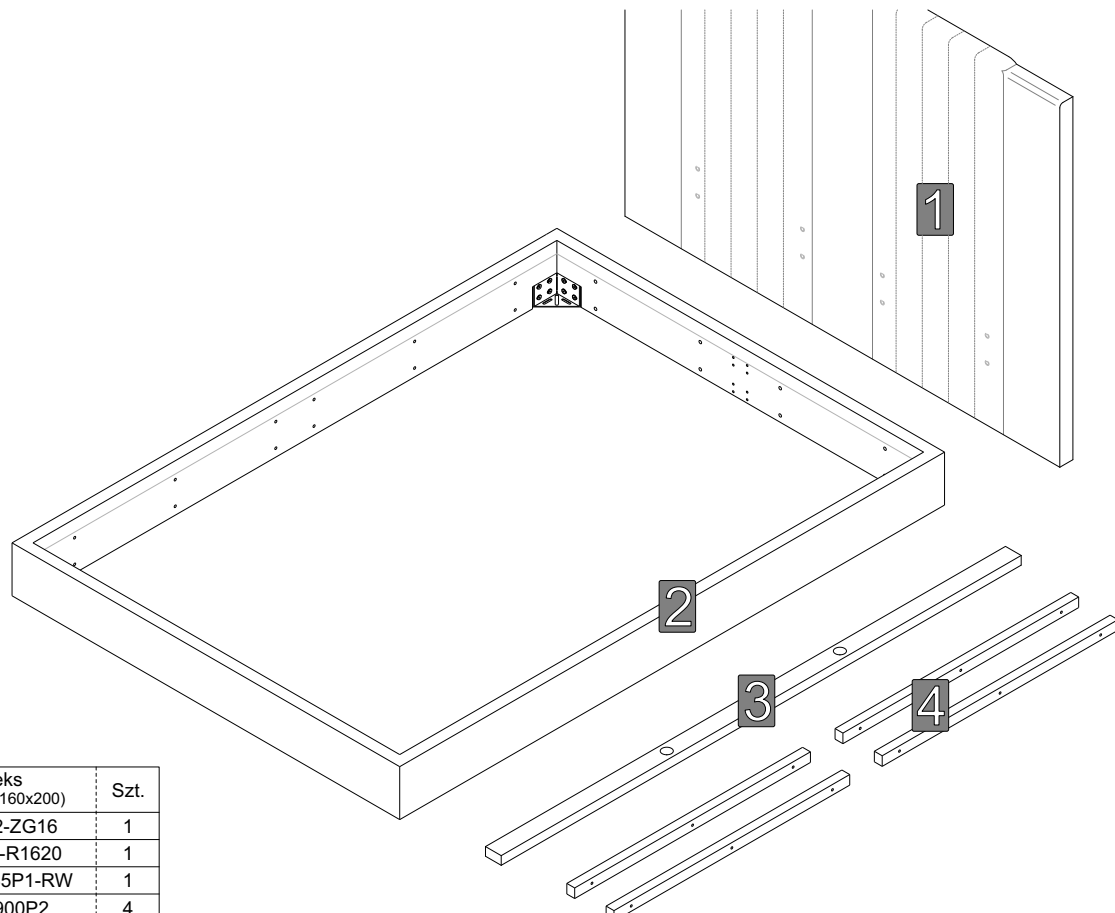



V1			V2
NOG-STA01-18-CZA	NOG-STA02-18-CZA	NOG-STA03-18-CZA	3
2 x			2 x





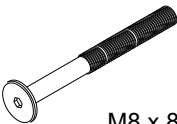
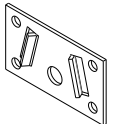

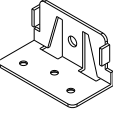
Nr	Indeks (dla rozm. 160x200)	Szt.
1	X-81242-ZG16	1
2	X-81240-R1620	1
3	X_LS-1985P1-RW	1
4	X_LP-900P2	4

Elementy w worku serwisowym
 Befestigungsmaterial im Servicebeutel
 Items in bag service
 Položky v sáčku služby

X_81240-WSD

A	B	C	D	E	F	G
						
M6 x 15	M6 x 70	M8 x 80		M4 x 40		4 x 20
4 x	12 x	8 x	2 x	8 x	2 x	6 x

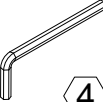
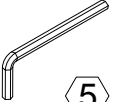
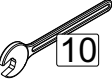
H	I	J	K	L	M	N	O
							
6x18x1,5	M6	M10x30x2,5	M8	4 x 16	4	5	10
4 x	4 x	8 x	8 x	4 x	1 x	1 x	1 x

Dodatkowe elementy niezbędne do sprawnego montażu
 Zusätzliche Komponenten für eine reibungslose Installation
 Additional components needed for a smooth assembly
 Ďalšie komponenty potrebné pre správny inštaláciu

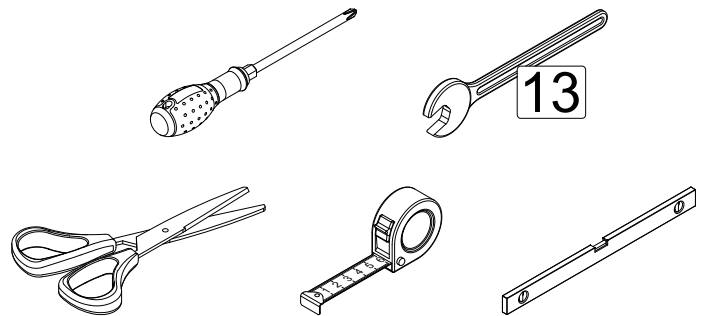

UWAGA

- odkryj wszystkie otwory / nawierty,
 które zamierzasz wykorzystać w trakcie montażu.

HINWEIS

- Entdecken Sie alle Öffnungen / Bohrungen,
 die Sie bei der Montage verwenden möchten.

PLEASE NOTE

- uncover all holes / gaps that you will use during the assembly.

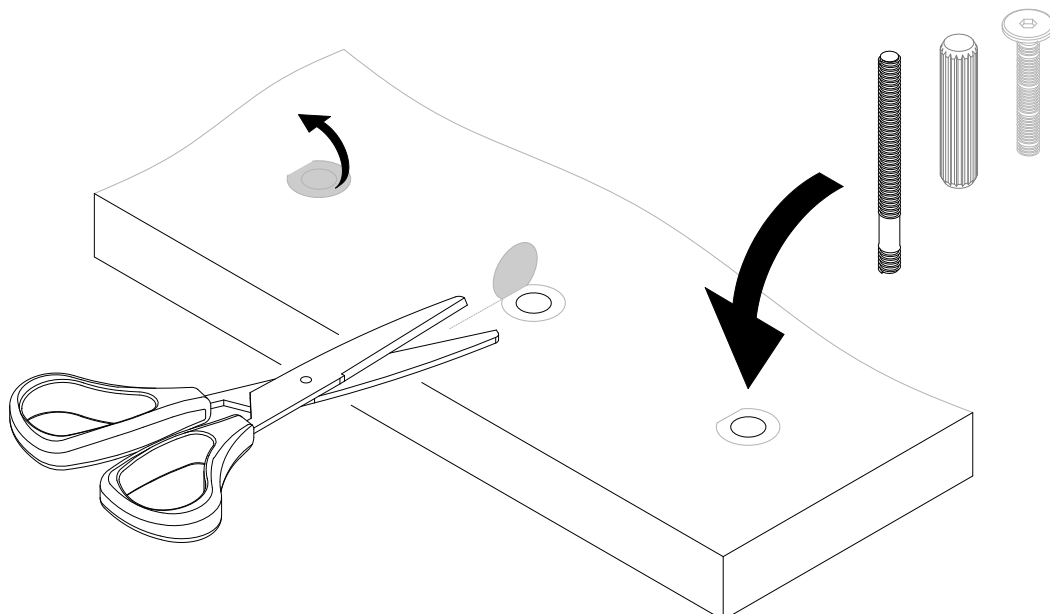



UWAGA - modele nog (do wyboru).

HINWEIS - Fußmodelle (zur Auswahl).

NOTE - models of legs (optional).

NOG-STA01-18-CZA

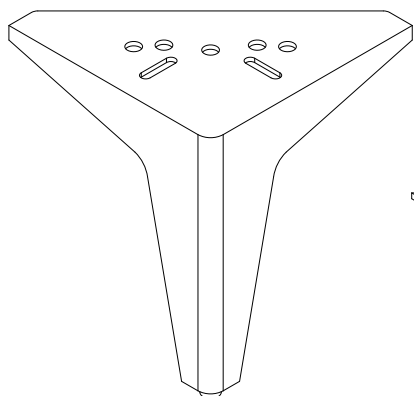

NOG-STA03-18-CZA

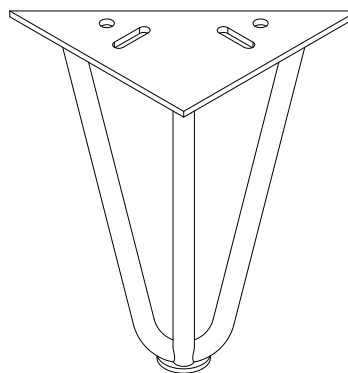

NOG-STA02-18-CZA

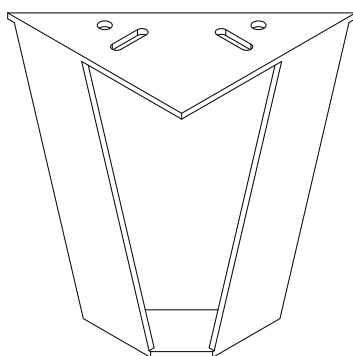

Instrukcja montażu - Aufbauanleitung - Assembly instruction - Návod na montáž

KROK
SCHRITT
STEP

1.

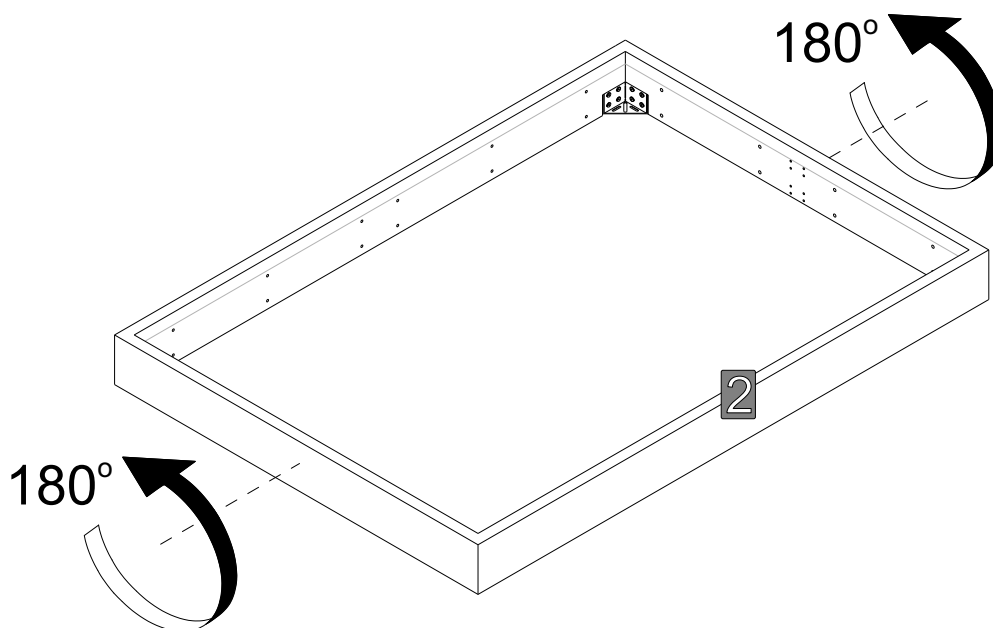

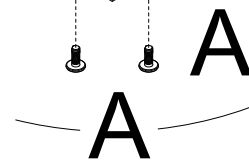
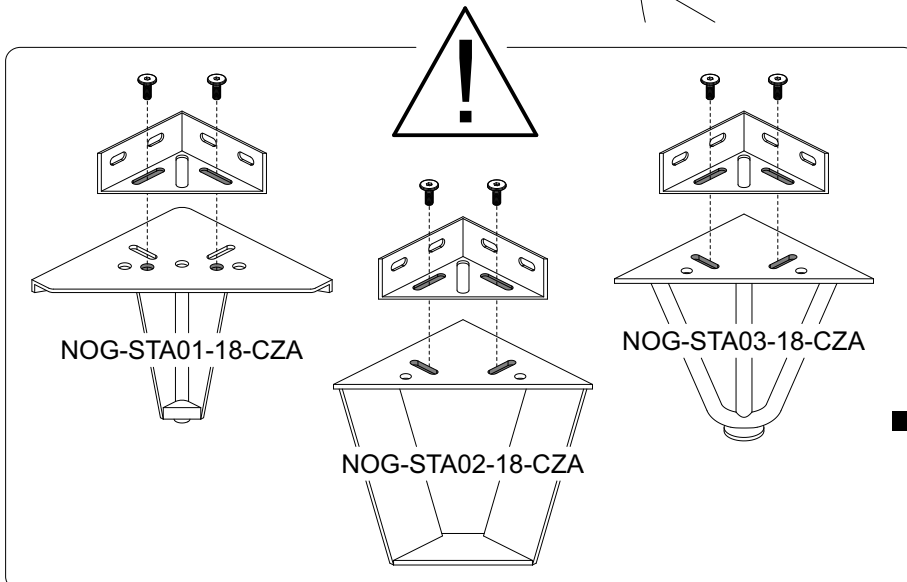
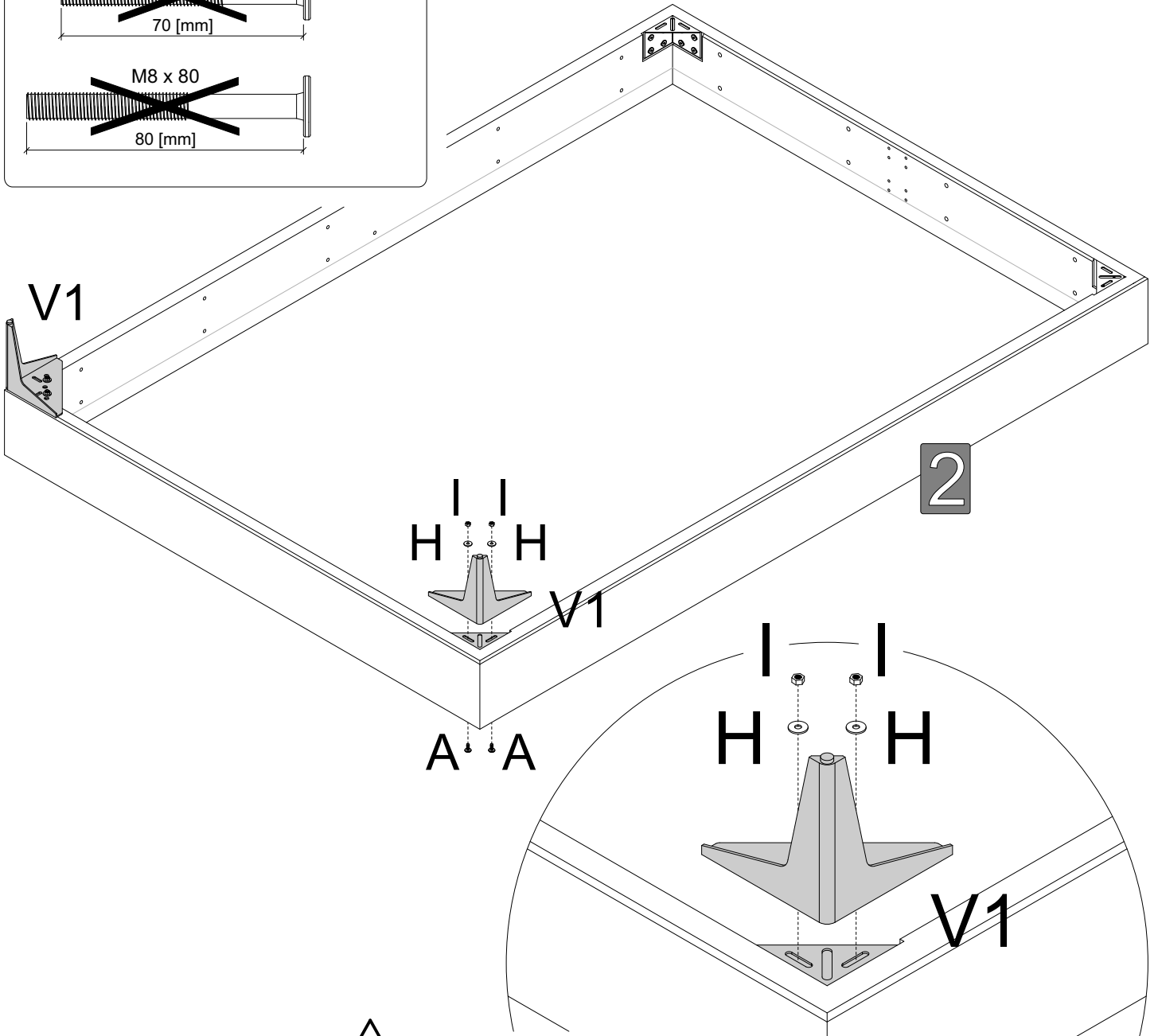
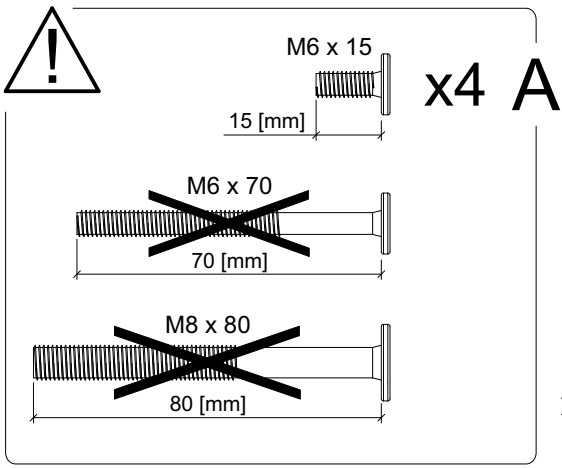

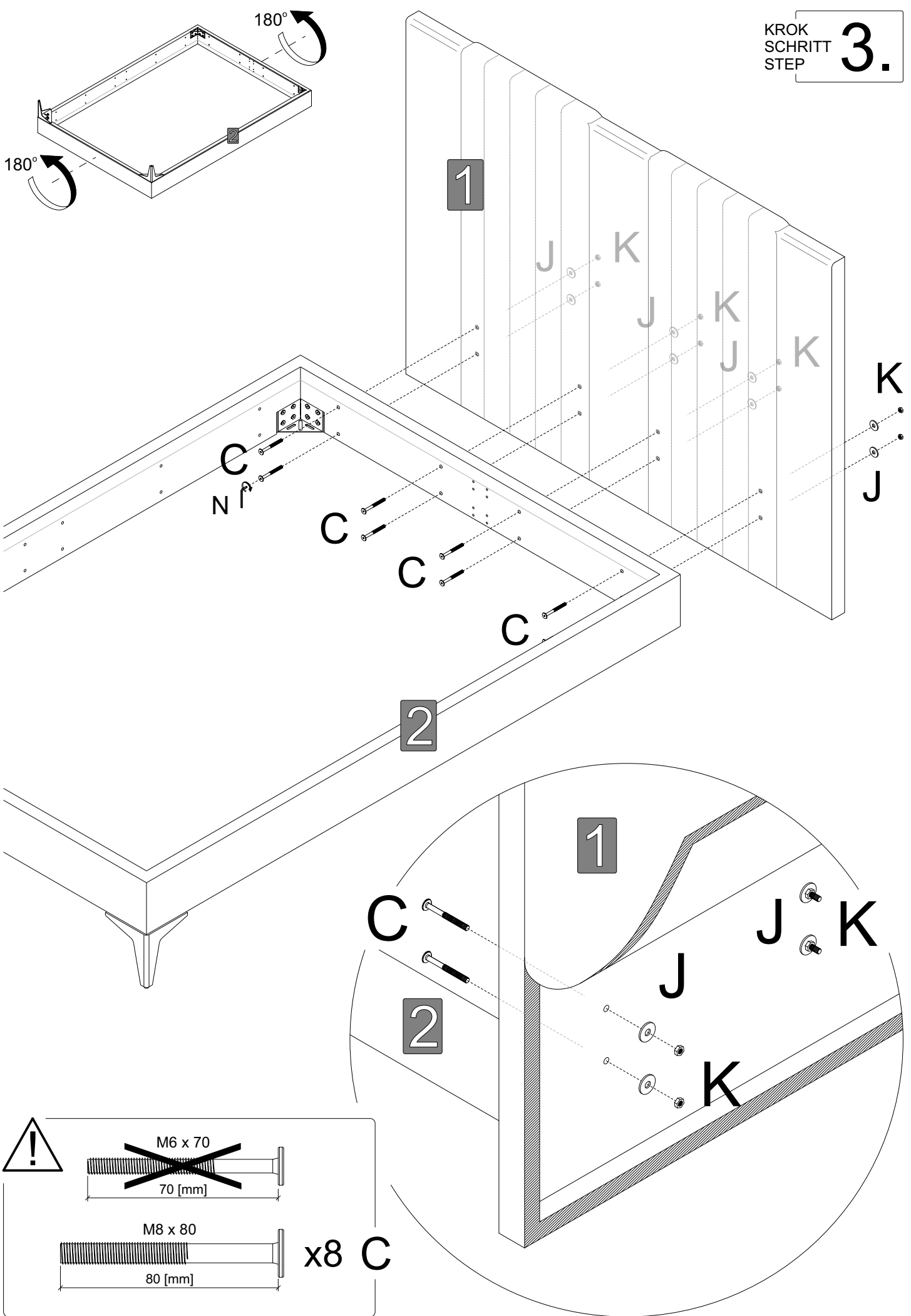



UWAGA - możliwość mocowania listew podtrzymujących stelaż na dwóch różnych wysokościach.

HINWEIS - Es besteht die Möglichkeit die Leisten des Lattenrahmens auf zwei verschiedenen Höhen zu montieren.

PLEASE NOTE - possible to assemble slats supporting the frame on two different heights (levels).

- 1 -

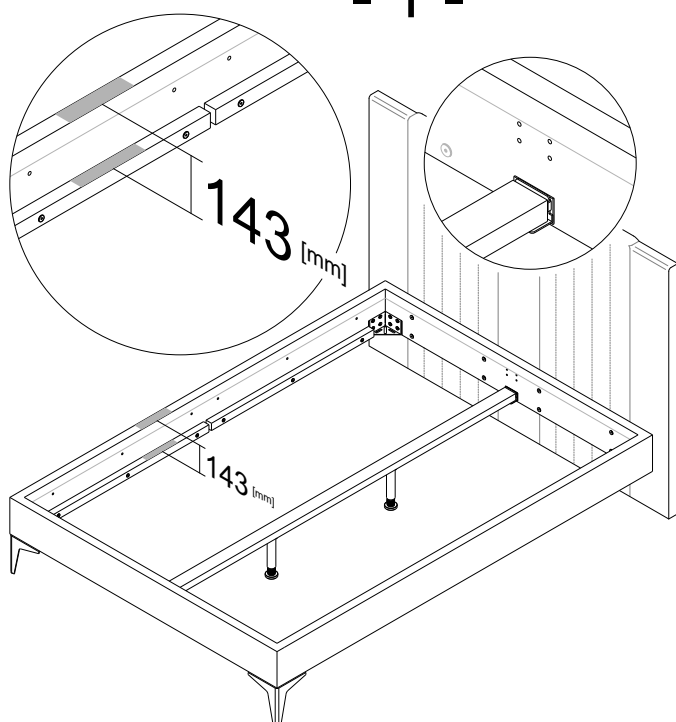

- 2 -

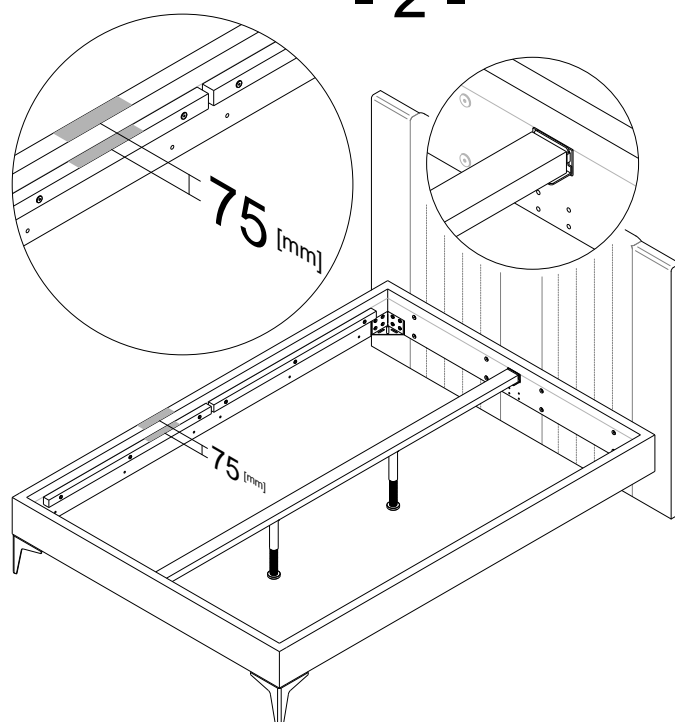

KROK
SCHRITT
STEP

4.

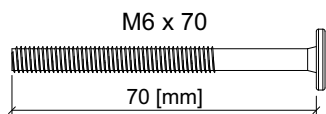

x12 B

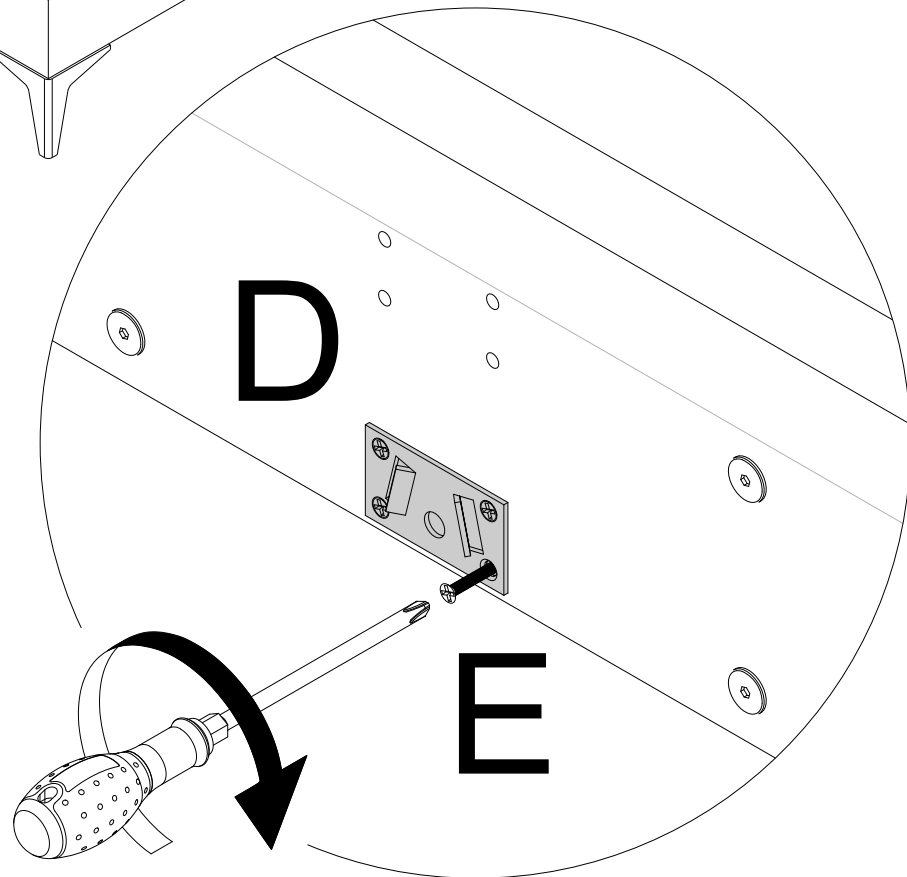
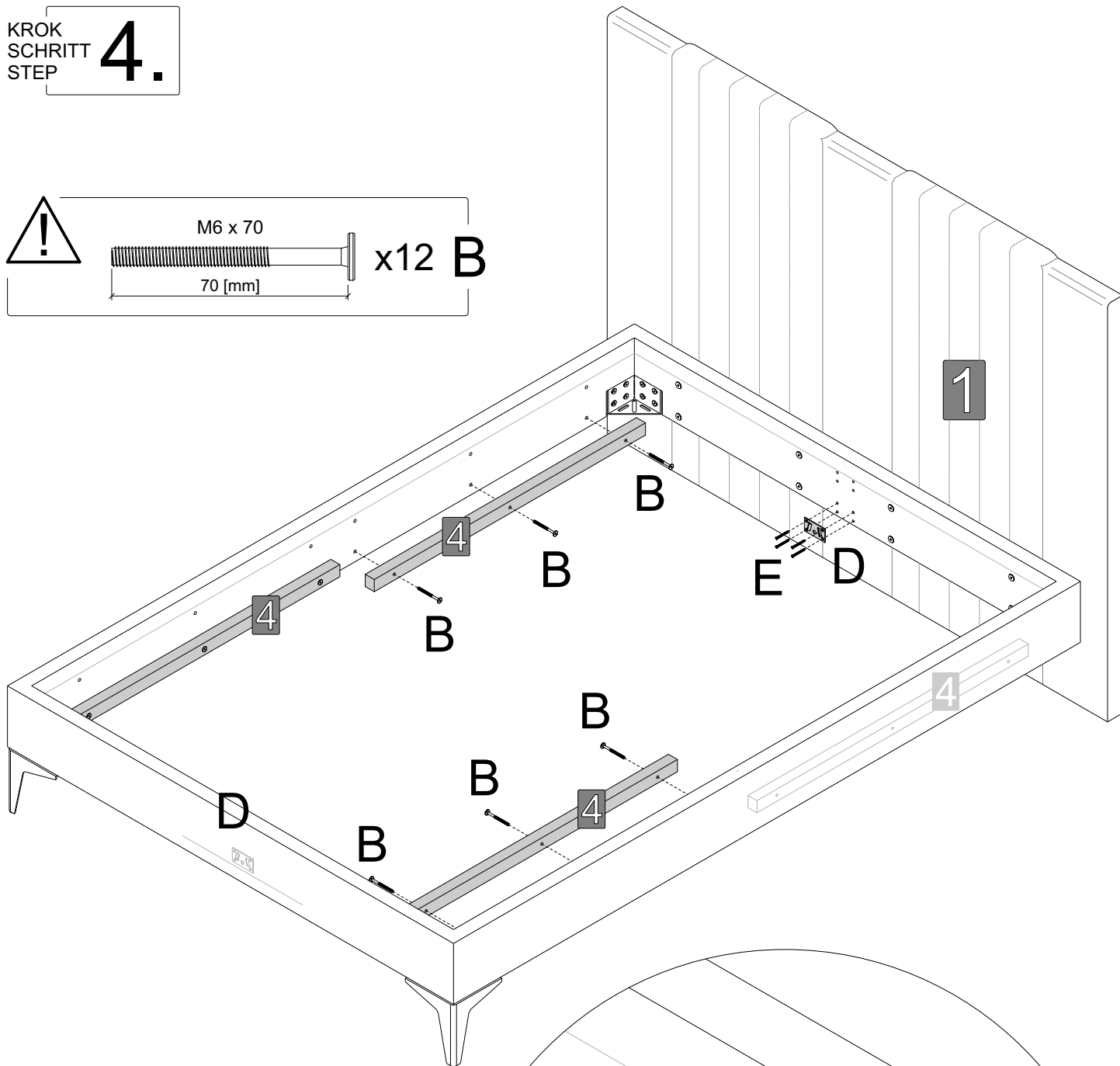

KROK
SCHRITT
STEP

5.

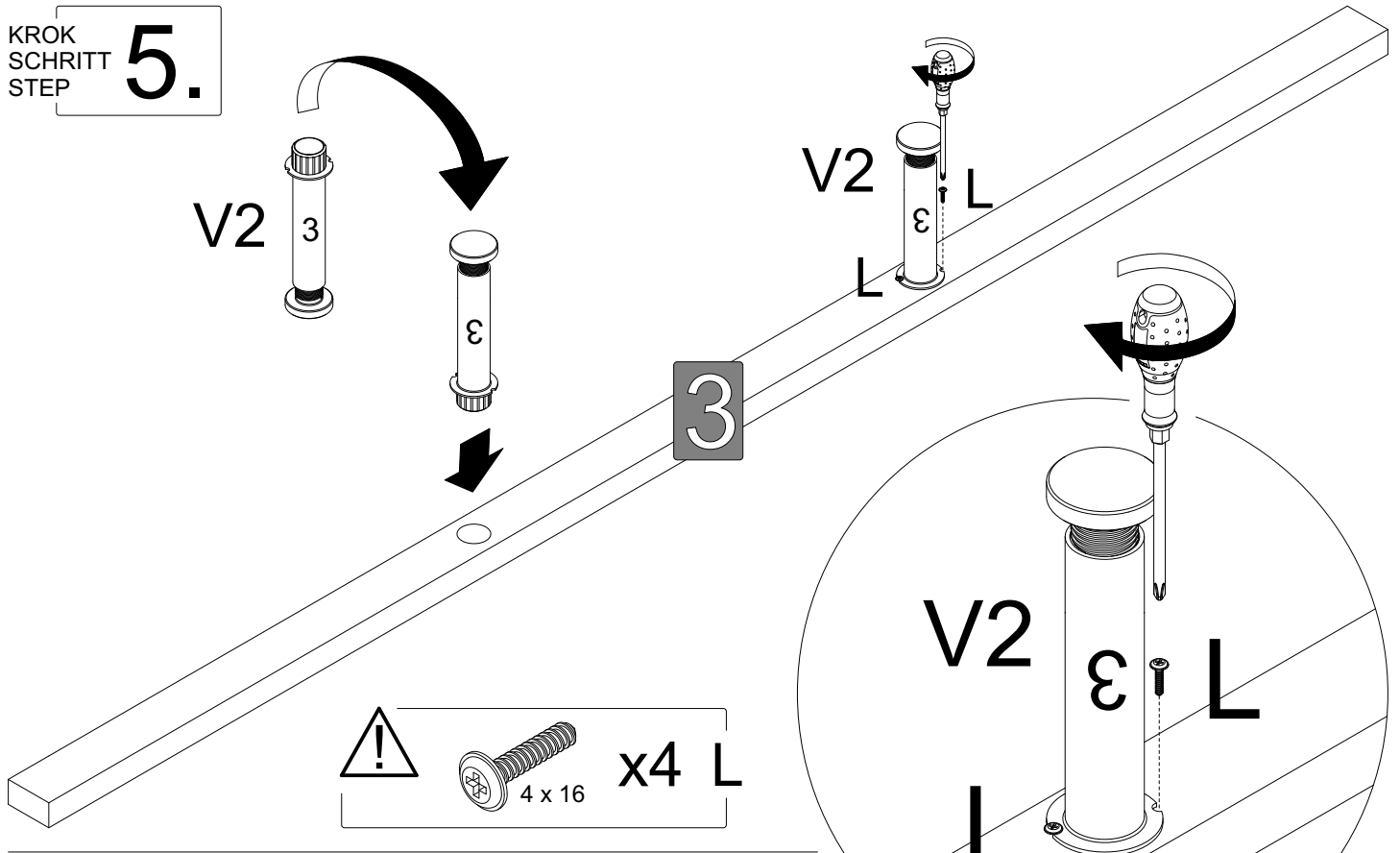

KROK
SCHRITT
STEP

6.

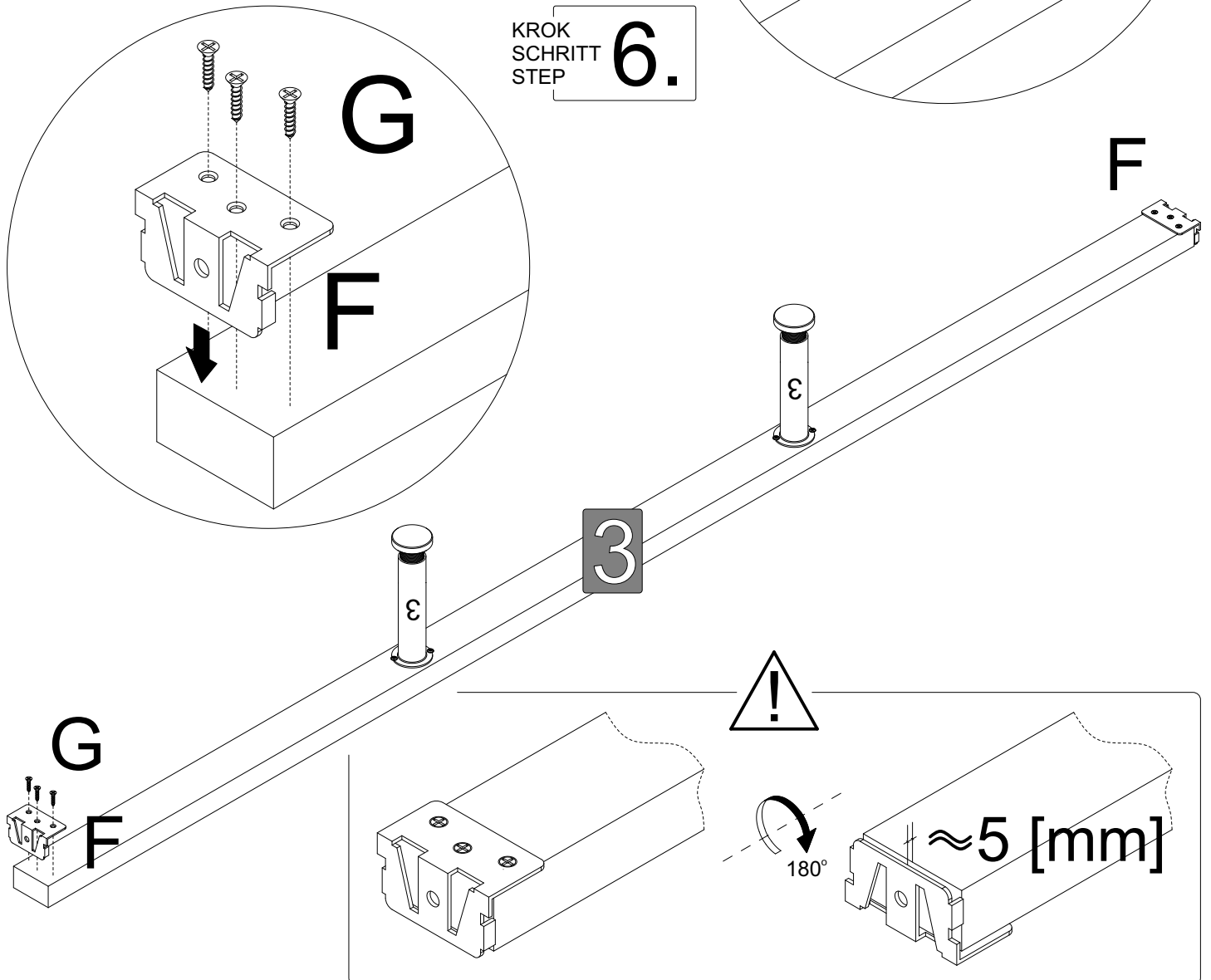

KROK
SCHRITT
STEP **7.**

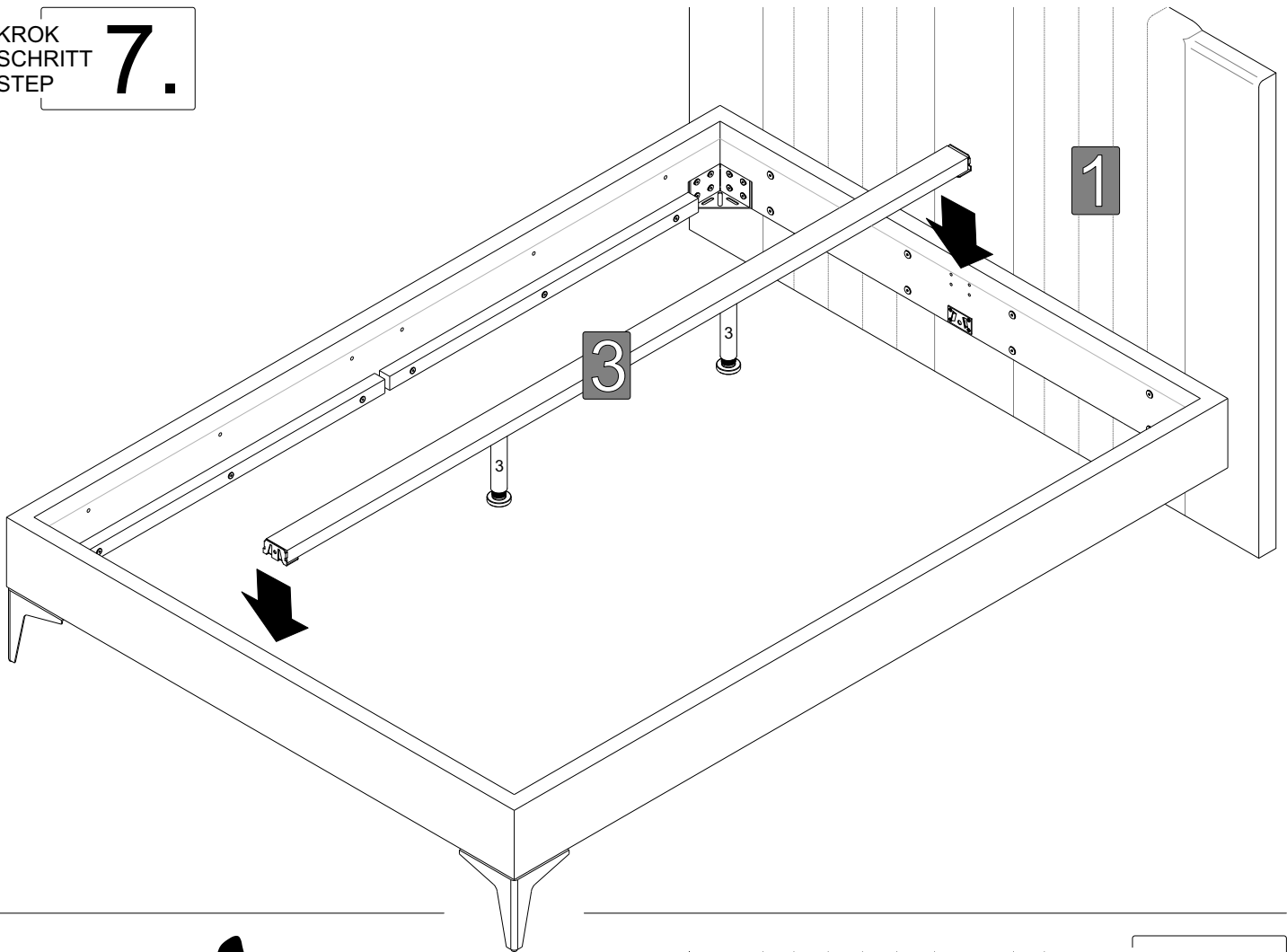

KROK
SCHRITT
STEP **8.**

